

## Product Data Sheet

# 3-Series Smart Outlet (Type E)

3200-Gfr

Centralite®

Last Updated: November 2018

## Product Overview

The 3-Series Smart Outlet (Type E) introduces new functionality to existing appliances and lighting devices. By placing the Smart Outlet between an outlet and any appliance in your home, you can instantly add advanced automation features. Not only can the Smart Outlet be switched on and off remotely, but it also can be used with your existing ZigBee hub to respond to alerts, schedules, and scenes. The Smart Outlet can also report its power usage for energy management. The 3-Series Smart Outlet (Type E) is an affordable way to add automation and track the energy use of your home.

## Dimensions

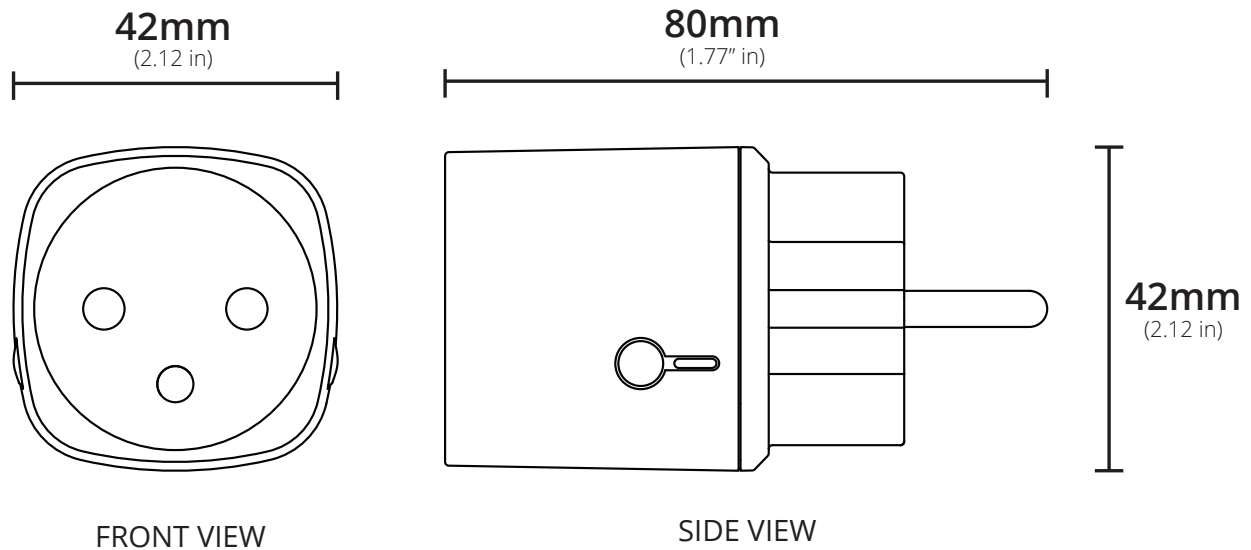

## In the Box:

1x - 3-Series Smart Outlet (Type E)

1x - Quick Start Guide

## Key Features:

- Current-sensing technology to report real-time energy usage.
- Easy compatibility with other manufacturers' ZigBee HA 1.2 devices.
- 2 Override buttons for direct on/off control.
- 2 LED indicator for at-a-glance on/off status.
- Over-the-air firmware updates.

## Use Cases

- Include appliances in your automated home schedules and events.
- Automatically turn off devices that are dangerous to leave on.
- Trigger coffee pot or toaster to turn on when there is motion in your bedroom in the morning.

### Turn your Crock-Pot into a “smart Crock-Pot.”

Plug-in your Crock-Pot to a 3-Series Smart Outlet (Type E) and experience “connected” cooking. Schedule your home to begin cooking at noon—no more coming home during your lunch break to start a meal.

### Automatically turn off devices that are dangerous to leave on.

Can't remember if you turned off the curling iron? Not only can the Smart Outlet automatically turn off a device after a set period of time, it can send you

- Measure energy usage of power-hungry devices.
- Be alerted if an appliance is turned on outside of scheduled times.
- Include window units and space heaters in your home automation system.

notifications and let you check the status of a device.

### Say no to energy-hungry devices

Many appliances still consume power, even when they're turned off. The Smart Outlet (Type E) lets you see how much power those devices are using and lets you shut them off to conserve electricity.

### Measure energy usage of appliances

The 3-Series Smart Outlet (Type E) features current sensing technology that actively reports energy usage. Your connected home can track energy usage and offer suggestions to save energy.

---

## Special Features

### Current-Sensing Circuitry

The 3-Series Smart Outlet (Type E) features current-sensing circuitry for real-time energy usage reporting. The current-sensing feature can also be used to notify users when a device has been turned on or off.

### High-quality, latching relays

The high-quality latching relay included in the Smart Outlet (Type E) is rated for loads up to 10 amps. This allows users the ability to safely control loads from larger, higher current devices like computers, monitors, TVs, coffee makers, and large stereo systems.

### Easy 2-Step Join Process

The Smart Outlet (Type E) is factory-configured to search for open ZigBee networks the first time it is plugged in. Simply open the hub for joining, plug in

the Smart Outlet (Type E), and the module will join the open network.

### ZigBee Home Automation 1.2 Compatibility

The 3-Series Smart Outlet (Type E) is fully ZigBee HA 1.2 certified and is guaranteed to function with all open, ZigBee HA 1.2-certified hubs and devices.

### Superior Range and Updatability

The Smart Outlet (Type E) supports over-the-air updates providing for seamless upgrades and feature additions without the need for any user interaction.

---

## Getting Started

### Step 1: Open ZigBee Network for Joining

Using your controller or hub's interface, enable the ZigBee network for joining.

### Step 2: Plug-In Smart Outlet

Plug the Smart Outlet into a receptacle and it will immediately begin searching for a network to join.

### Step 3: Finish Joining at Hub (optional)

Some hubs and controllers require additional steps such as naming or categorizing the device.

---

## Troubleshooting

### Unplug Module from Receptacle

Begin by unplugging the module from the wall receptacle. Then plug it in again and test operation. Also, try plugging the lamp or appliance into a non-switched wall receptacle to ensure the lamp works.

### Step 2: Factory Reset and Rejoin

Unplug any devices from the module and unplug from the wall. Now hold the on/off button while plugging it back into the wall. Hold the button until the status LED turns on. Repeat the “Getting Started” steps to rejoin the ZigBee network.

## Compatibility

The 3-Series Smart Outlet (Type E) features out-of-the-box compatibility with any ZigBee HA 1.2-certified hub, controller, bridge, or platform.

---

## Technical Specifications

### Electrical

Rated: 240 VAC, 50Hz  
Output: 10A, General Purpose

### Environmental

Operating Temperature: 0° to 40°C

### Shipping / Storage

Temperature: -20° to 50°C  
Humidity Range: 0 to 90% RH.  
(non-condensing)

### Approvals:



### Wireless RF

Protocol: ZigBee HA 1.2  
TX Strength: +8 dBm  
RF Channels: 16  
Range: 130+ ft. (40+ m) L.O.S.  
Temp Accuracy: ±1.8 °C (max), -10 to 85 °C  
Precision: ± 0.1 °C

---

## Safety Warnings

### NOTE:

Each module outlet is rated to 10A only if the connecting cord is rated at 90C or greater.

### WARNING!

If a load greater than 10 amps is attached to the output, the Smart Outlet will be damaged and will no longer function.

### WARNING!

The total current limit of the device is 10A. Do not exceed this value!

### WARNING!

If a direct short is created on the output, the Smart Outlet will be damaged and will no longer function.

---

## Support

Centralite offers both Tier-1 and Tier-2 support structures to meet the needs of different customers. For those customers that provide existing, in-house support for systems, Centralite can serve as Tier-2 support specialists. For Centralite retail-branded products, Centralite provides direct Tier-1 support for all products.

---

## Standard Warranty

Centralite offers a standard 26-month exchange warranty on the 3-Series Smart Outlet (Type E).

Additional mandatory warranty period in compliance with local law product is being sold.

---

## Contact Sales

For more information about sales or distribution, please contact:

877-466-5483  
+1 251-607-9119 (Int'l)  
sales@centralite.com

Centralite Systems, Inc.  
1701 Industrial Park Drive  
Mobile, AL 36693

<http://centralite.com>

**Notice:** Any content, factual information, or specifications containing errors in this document are solely inadvertent and will be corrected upon discovery. Specifications for unreleased/planned products are subject to change.

---