



# JetPak Installation Guide

**Installer's Guide**

## Table of Contents

<b>1. Section 1: Introduction.....</b>	<b>1</b>
<b>2. Section 2: Installation Instructions .....</b>	<b>2</b>
Connecting Centralite to Elk M1-Gold .....	2
Connecting RCS Thermostats to Elk M1-Gold .....	4
Testing CentraLite Communication .....	6
Testing .....	8
Testing RCS Thermostat Communication .....	8
Appendix A .....	9

## Section 1: Introduction

The Centralite JetPak is an accessory package that allows a LiteJet or Elegance users to interface an Elk M1Gold Home Automation System. This system will allow the user to use the Elk M1Gold's powerful If/Then logic to accomplish complex home automation task as well as interface their system with HVAC control. Complex task can be reduced to a single button press or timed event using the JETPAK. For example, whenever the alarm is armed for AWAY the system would trigger the Away lighting scene and set the HVAC to a predetermined temperature, saving money on lighting and heating and cooling cost.

**Figure 1  
Basic Layout**

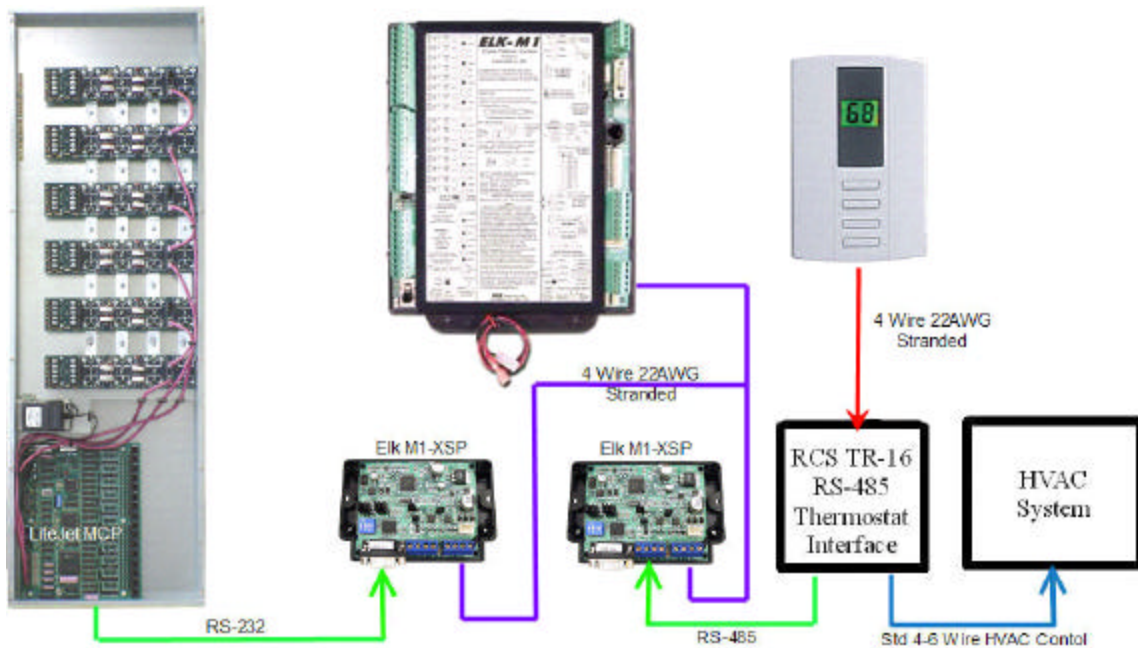

The CentraLite LiteJet and Elegance has the ability to communicate bi-directionally with third party applications. Communication is facilitated by the two third party RS-232 ports built into the Master Control Panel (MCP). Connection to an Elk Products M1-Gold is simple and straight forward using the Elk M1-XSP.

In order to connect your LiteJet to the M1Gold you need one Elk Products Serial Expander Port (M1XSP). If you are using RCS thermostats you will need an additional M1XSP to communicate between the M1Gold and the RCS thermostats interface (RCS TR-16 or TR-40). The M1Gold supports 16 thermostats using the RS-485 protocol.

## Section 2: Installation Instructions

### Connecting Centralite to ELK M1-Gold

**Note: Make sure to turn off all power for Centralite and Elk M1-Gold before performing any work.**

**Figure 2**  
Centralite to M1-XSP

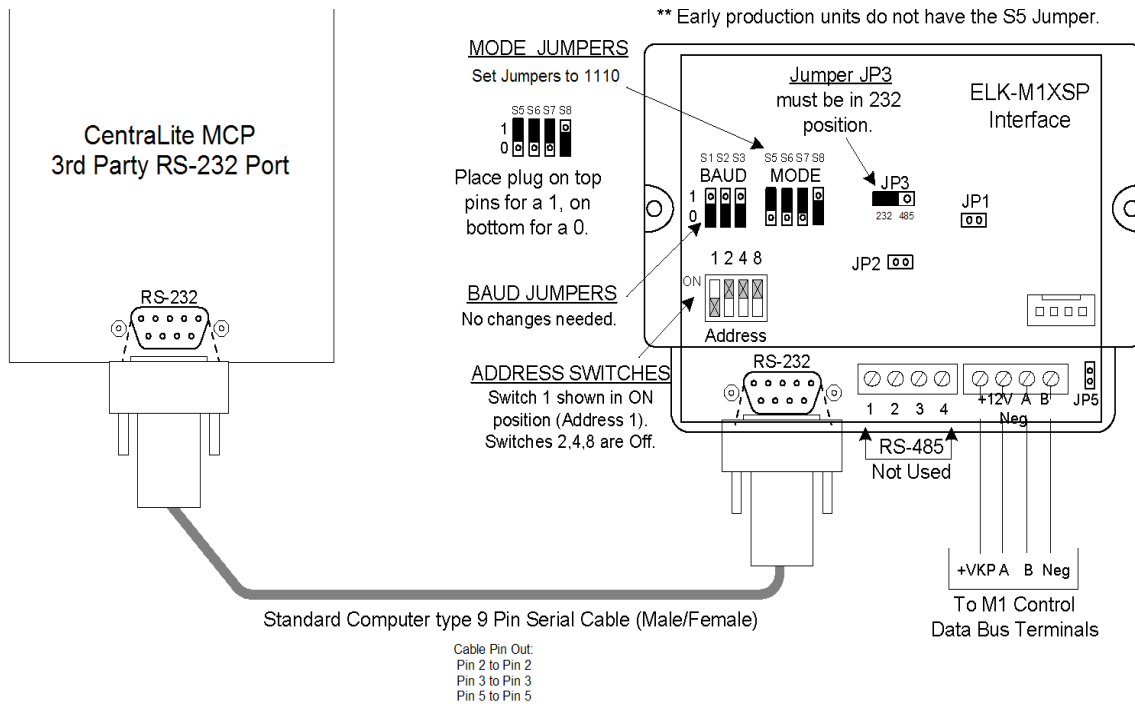

#### 1. Connect the LiteJet to the M1-XSP.

Connect Systems using a straight through DB-9 cable using pins 2, 3 and 5 between the two RS-232 ports.

#### 2. Connect the M1-XSP to the M1-Gold's RS-485 Keypad bus.

Connect terminals +12V, A, B, and Neg from the M1XSP to the M1's Keypad Data Bus (terminals +VKP, Data A, Data B, & Neg). NOTE: Refer to the M1 Installation Manual and the EOL Termination information at the end of this manual about proper connections of data bus devices with multiple homerun cables.

**3. Set address jumpers on M1-XSP.**

There are 4 address switches, each with a position of OFF or ON (binary value 0 or 1) and decimal equivalent value of (1, 2, 4, or 8). The total decimal value of the "ON" switches equates to the data bus address. As a rule, the first M1XSP should be set to address 1. If more than 1 M1XSP is installed, set each one to a unique (sequential) address (2, 3, etc). Refer to the following chart for Data Bus Address settings.

Data Bus Address	Switch Settings			
	S1	S2	S3	S4
1	On	Off	Off	Off
2	Off	On	Off	Off
3	On	On	Off	Off
4	Off	Off	On	Off
5	On	Off	On	Off
6	Off	On	On	Off
7	On	On	On	Off

**Table 1**  
**Data Bus Address Settings**

**4. Set Mode Jumpers for Centralite.**

The Mode Jumpers S5-S8 should be set to 1110 which configures the M1-XSP for communication with a Centralite System. These jumper settings are shown in Figure 2.

**5. After all connections are complete, turn On the M1 Master Power Switch and Centralite MCP.****6. Enroll the M1XSP into the M1 Control as follows:**

From the Keypad access the Installer level programming by pressing the "Elk" button and then "9" then pressing the right arrow key. Enter the Installer Code (172839 by default). Select "Menu 01-Bus Module Enrollment". Press the right arrow key to start the enrollment. When the keypad indicates enrollment complete, press the right arrow key to view the results. Among the displayed enrolled devices there should be a type 5 (T5) device at address 01.

**Note: If it becomes necessary to replace an already installed M1XSP, set the new unit to the same address as the old unit and repeat this enrollment process. If a device is permanently removed, the enrollment process must be performed in order to de-enroll the unit and thereby prevent a "missing" trouble condition.**

**Note: Diagnostic LED indication**

**Slow blink (1/2 sec.) = Normal communication with M1.**

**Fast flicker = Communicating with other equipment (Thermostat, Lighting Controller, PC, etc.)**

**No blink = No communication with M1. Unit might be unplugged or powered off.**

**If you are not integrating RSC Thermostats skip to the section "Testing Centralite Communication".**

## Connecting RCS Thermostats to Elk M1-Gold

### 1. Connect the M1-XSP to the M1-Gold's RS-485 Keypad bus.

Connect terminals +12V, A, B, and Neg from the M1XSP to the M1's Keypad Data Bus (terminals +VKP, Data A, Data B, & Neg). NOTE: Refer to the M1 Installation Manual and the EOL Termination information at the end of this manual about proper connections of data bus devices with multiple homerun cables.

### 2. Install, and wire the RCS Control Unit and Wall Display Units.

Connect the Wall displays "CU" terminals (-,+ ,C,D) to the Control Unit's terminals (GND, +V,C,D).

### 3. Connect the RCS TR-16 to the HVAC system.

Follow the RCS manual for connections to a standard HVAC unit.

### 4. Connect the RCS TR-16 to the M1-XSP.

Follow the connections shown in Figure 3.

**Note: If you are using more than one TR-16 or TR-40 connect each thermostat's Control Unit to the M1-XSP RS-485 port in parallel.**

Figure 3  
TR-16 to M1-XSP

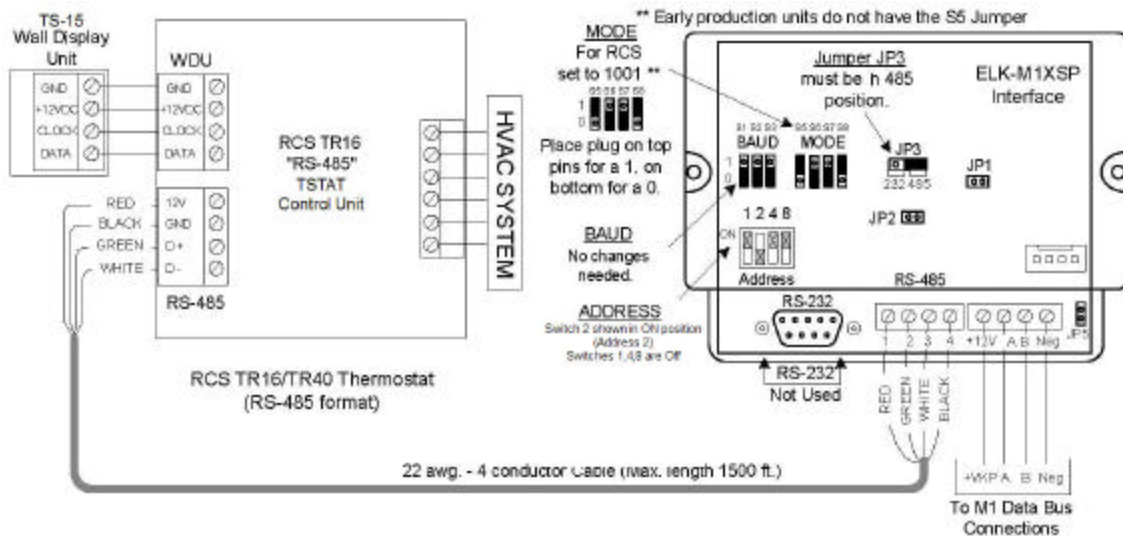

Using the RS-485 format, up to 16 RCS TR16/TR40 Thermostats total can be interfaced to an ELK-M1G (Gold) using 1 M1XSP. Each thermostat must have a unique address from 1 to 16.

**5. Set the Mode Jumpers**

S5=1, S6=0, S7=0, & S8=1 for RCS mode. If the M1XSP has jumper S4, set it to =1. Set Jumper JP3 to the "485" position. The BAUD jumpers S1,S2, & S3 do not matter as the RCS baud rate is preset internally.

**6. Power up the RCS Thermostat Control Unit.**

Turn on the M1-Gold master power switch so that the M1-XSP will turn on and power the TR-16. Once the TR-16 is turned on, address all of the TS-15 Wall Display Thermostats per the RCS instructions. The unit address must match the Thermostat number in the M1 Control. The first Thermostat should be Address 1.

**7. Enroll the M1XSP into the M1 Control as follows:**

From the Keypad access the Installer level programming by pressing the "Elk" button and then "9" then pressing the right arrow key. Enter the Installer Code (172839 by default). Select "Menu 01-Bus Module Enrollment". Press the right arrow key to start the enrollment. When the keypad indicates enrollment complete, press the right arrow key to view the results. Among the displayed enrolled devices there should be a type 5 (T5) device at address 01.

**Note: If it becomes necessary to replace an already installed M1XSP, set the new unit to the same address as the old unit and repeat this enrollment process. If a device is permanently removed, the enrollment process must be performed in order to de-enroll the unit and thereby prevent a "missing" trouble condition.**

**Note: Diagnostic LED indication**

**Slow blink (1/2 sec.) = Normal communication with M1.**

**Fast flicker = Communicating with other equipment (Thermostat, Lighting Controller, PC, etc.)**

**No blink = No communication with M1. Unit might be unplugged or powered off.**

**Continue to the section "Testing Thermostat Communication"**

## Testing Centralite Communication

### Description:

Centralite integration is via "mapped" assignments with M1 Lighting devices 1-256. Light devices 1-192 allow direct (On/Off/ Dim) control of loads 1-192 respectively. From ElkRP, program Lights 1-192 as "Format=Serial Expander", Type =Dimmer".

Light devices 193-256 allow pre-programmed Centralite "Scenes" 1-64 to be turned On/Off. Program light devices 193-256 as "Format=Serial Expander", "Type=On/Off Switch".

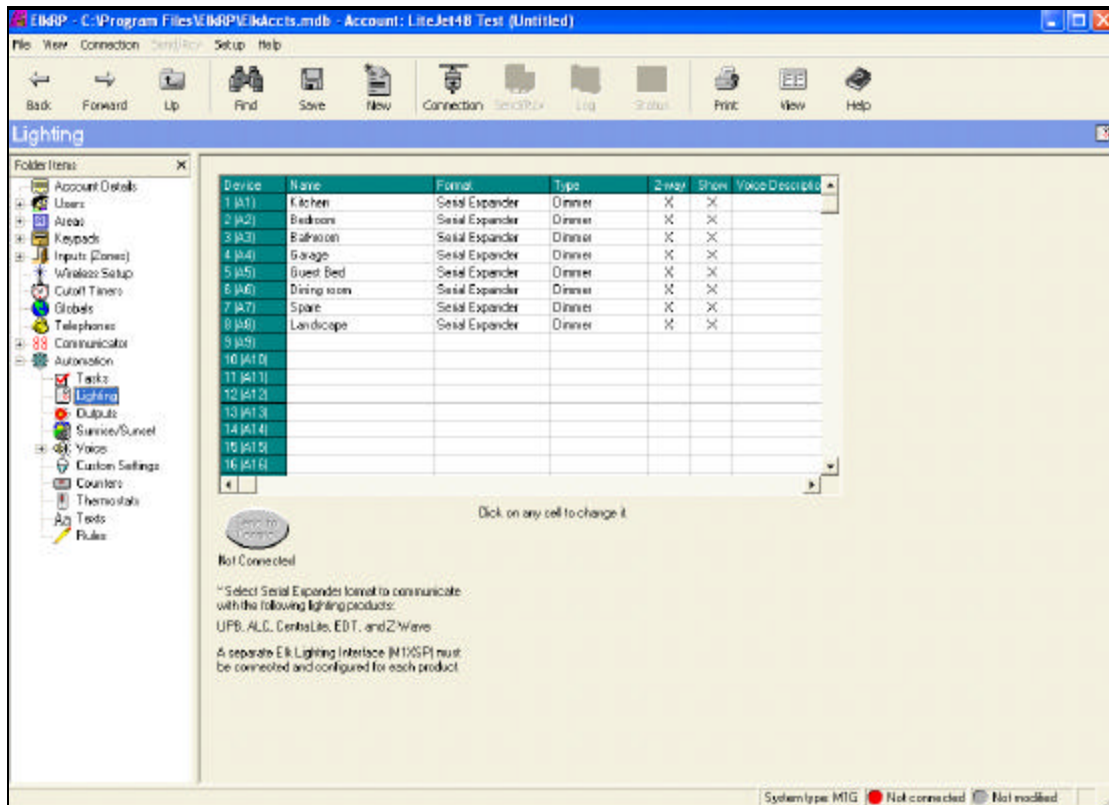

Whenever a M1 Light device is turned On or Off from a rule or from the M1 Keypad "Automation" menu, the corresponding Centralite serial command (load or scene) is sent from the M1XSP. Dim commands can only be sent from a rule. The M1 can even receive "Load Status" changes from Centralite, provided the M1XSP has firmware ver. 1.0.12 or greater and the Centralite processor has ver. 5.5 or greater. NOTE: The M1 does react directly to button presses from a Centralite keypad. However, it is possible to assign a load to a button (a dummy load) and use the status change of that load to trigger a M1 rule. The following cross reference map illustrates the relation between M1 Light Devices and Centralite Loads/Scenes. The PLC column is for reference only.

**Table 2**  
**Centralite Device Mapping**

ELK Light Device #	PLC (X- 10) Ref.	Centralite Load	ELK Light Device #	PLC (X- 10) Ref.	Centralite Load	ELK Light Device #	PLC (X- 10) Ref.	Centralite Load	ELK Light Device #	PLC (X-10) Ref.	Centralite
1	A01	Load 1	65	E01	Load 65	129	I01	Load 129	193	M01	Scene 01 All On
2	A02	Load 2	66	E02	Load 66	130	I02	Load 130	194	M02	Scene 02 All Off
3	A03	Load 3	67	E03	Load 67	131	I03	Load 131	195	M03	Scene 03 Vacation
4	A04	Load 4	68	E04	Load 68	132	I04	Load 132	196	M04	Scene 04 Alarm Flash
5	A05	Load 5	69	E05	Load 69	133	I05	Load 133	197	M05	Scene 05 Pur-up Override
6	A06	Load 6	70	E06	Load 70	134	I06	Load 134	198	M06	Scene 06
7	A07	Load 7	71	E07	Load 71	135	I07	Load 135	199	M07	Scene 07
8	A08	Load 8	72	E08	Load 72	136	I08	Load 136	200	M08	Scene 08
9	A09	Load 9	73	E09	Load 73	137	I09	Load 137	201	M09	Scene 09
10	A10	Load 10	74	E10	Load 74	138	I10	Load 138	202	M10	Scene 10
11	A11	Load 11	75	E11	Load 75	139	I11	Load 139	203	M11	Scene 11
12	A12	Load 12	76	E12	Load 76	140	I12	Load 140	204	M12	Scene 12
13	A13	Load 13	77	E13	Load 77	141	I13	Load 141	205	M13	Scene 13
14	A14	Load 14	78	E14	Load 78	142	I14	Load 142	206	M14	Scene 14
15	A15	Load 15	79	E15	Load 79	143	I15	Load 143	207	M15	Scene 15
16	A16	Load 16	80	E16	Load 80	144	I16	Load 144	208	M16	Scene 16
17	B01	Load 17	81	F01	Load 81	145	J01	Load 145	209	N01	Scene 17
18	B02	Load 18	82	F02	Load 82	146	J02	Load 146	210	N02	Scene 18
19	B03	Load 19	83	F03	Load 83	147	J03	Load 147	211	N03	Scene 19
20	B04	Load 20	84	F04	Load 84	148	J04	Load 148	212	N04	Scene 20
21	B05	Load 21	85	F05	Load 85	149	J05	Load 149	213	N05	Scene 21
22	B06	Load 22	86	F06	Load 86	150	J06	Load 150	214	N06	Scene 22
23	B07	Load 23	87	F07	Load 87	151	J07	Load 151	215	N07	Scene 23
24	B08	Load 24	88	F08	Load 88	152	J08	Load 152	216	N08	Scene 24
25	B09	Load 25	89	F09	Load 89	153	J09	Load 153	217	N09	Scene 25
26	B10	Load 26	90	F10	Load 90	154	J10	Load 154	218	N10	Scene 26
27	B11	Load 27	91	F11	Load 91	155	J11	Load 155	219	N11	Scene 27
28	B12	Load 28	92	F12	Load 92	156	J12	Load 156	220	N12	Scene 28
29	B13	Load 29	93	F13	Load 93	157	J13	Load 157	221	N13	Scene 29
30	B14	Load 30	94	F14	Load 94	158	J14	Load 158	222	N14	Scene 30
31	B15	Load 31	95	F15	Load 95	159	J15	Load 159	223	N15	Scene 31
32	B16	Load 32	96	F16	Load 96	160	J16	Load 160	224	N16	Scene 32
33	C01	Load 33	97	G01	Load 97	161	K01	Load 161	225	O01	Scene 33
34	C02	Load 34	98	G02	Load 98	162	K02	Load 162	226	O02	Scene 34
35	C03	Load 35	99	G03	Load 99	163	K03	Load 163	227	O03	Scene 35
36	C04	Load 36	100	G04	Load 100	164	K04	Load 164	228	O04	Scene 36
37	C05	Load 37	101	G05	Load 101	165	K05	Load 165	229	O05	Scene 37
38	C06	Load 38	102	G06	Load 102	166	K06	Load 166	230	O06	Scene 38
39	C07	Load 39	103	G07	Load 103	167	K07	Load 167	231	O07	Scene 39
40	C08	Load 40	104	G08	Load 104	168	K08	Load 168	232	O08	Scene 40
41	C09	Load 41	105	G09	Load 105	169	K09	Load 169	233	O09	Scene 41
42	C10	Load 42	106	G10	Load 106	170	K10	Load 170	234	O10	Scene 42
43	C11	Load 43	107	G11	Load 107	171	K11	Load 171	235	O11	Scene 43
44	C12	Load 44	108	G12	Load 108	172	K12	Load 172	236	O12	Scene 44
45	C13	Load 45	109	G13	Load 109	173	K13	Load 173	237	O13	Scene 45
46	C14	Load 46	110	G14	Load 110	174	K14	Load 174	238	O14	Scene 46
47	C15	Load 47	111	G15	Load 111	175	K15	Load 175	239	O15	Scene 47
48	C16	Load 48	112	G16	Load 112	176	K16	Load 176	240	O16	Scene 48
49	D01	Load 49	113	H01	Load 113	177	L01	Load 177	241	P01	Scene 49
50	D02	Load 50	114	H02	Load 114	178	L02	Load 178	242	P02	Scene 50
51	D03	Load 51	115	H03	Load 115	179	L03	Load 179	243	P03	Scene 51
52	D04	Load 52	116	H04	Load 116	180	L04	Load 180	244	P04	Scene 52
53	D05	Load 53	117	H05	Load 117	181	L05	Load 181	245	P05	Scene 53
54	D06	Load 54	118	H06	Load 118	182	L06	Load 182	246	P06	Scene 54
55	D07	Load 55	119	H07	Load 119	183	L07	Load 183	247	P07	Scene 55
56	D08	Load 56	120	H08	Load 120	184	L08	Load 184	248	P08	Scene 56
57	D09	Load 57	121	H09	Load 121	185	L09	Load 185	249	P09	Scene 57
58	D10	Load 58	122	H10	Load 122	186	L10	Load 186	250	P10	Scene 58
59	D11	Load 59	123	H11	Load 123	187	L11	Load 187	251	P11	Scene 59
60	D12	Load 60	124	H12	Load 124	188	L12	Load 188	252	P12	Scene 60
61	D13	Load 61	125	H13	Load 125	189	L13	Load 189	253	P13	Scene 61
62	D14	Load 62	126	H14	Load 126	190	L14	Load 190	254	P14	Scene 62
63	D15	Load 63	127	H15	Load 127	191	L15	Load 191	255	P15	Scene 63
64	D16	Load 64	128	H16	Load 128	192	L16	Load 192	256	P16	Scene 64

\*\* Scene 1 for Elegance is ALL ON/OFF, Scene 2 is Vacation Mode, Scene 3 is Alarm Flash, and Scene 4 is the first user definable scene.

## Testing:

Using the ELK-RP Software, program the M1 using the following steps. Open a new File. Connect to the system using the serial connection. Next click on the Automation Tab in the RP Software and select Lighting. Setup Devices 1,2,3, 193 and 194. Give each device a name and type: Serial Expander. Since devices 1-192 are loads give them Type: Dimmer. Devices 193-255 will be mapped to Centralite Scenes 1-64. Give these devices Type:On/Off Switch. Next go to the "Rules" page and create a few rules for testing.

### Make the following rules:

Whenever F1 Key on ANY Keypad Activates  
Then turn [load 1] ON

Whenever F2 Key on ANY Keypad Activates  
Then Turn On Load [193 M1]

Now pressing the Keypad button F1 should turn on CentraLite load 1 and F2 should turn on the All On scene. If this works properly the two systems are communicating properly.

## Testing RCS Thermostat Communication

Using the ELK-RP Software, program the M1 using the following steps. Test and verify operation using steps 1d and 1e.

- 1a. Click on the Automation Tab in the ELK-RP software. Click on Thermostat icon and program a name for Thermostat 1.
- 1b. Click on the Task icon and program at least two tasks. Name the 1st Task "Economy Mode" and the 2nd "Comfort Mode".
- 1c. Click on the Rules icon and create the following 4 rules.

Whenever [Area Name] Armed State Becomes Armed Away Whenever [Task Name] (Task 1) Is Activated Then Activate [Economy Mode] (Task 1) Then Set [Thermostat 1] (TStat 1) Cooling Desired Temp to 85 degrees

Whenever [Area] Armed State Becomes Disarmed Whenever [Task Name] (Task 2) Is Activated Then Activate [Comfort Mode] (Task 2) Then Set [Thermostat 1] (TStat 1) Cooling Desired Temp to 70 degrees

- 1d. Use the M1 Keypad to verify the M1XSP & Thermostat operation. Press the ELK key followed by the Right arrow key to access Menu 1-View/Control Automation Fncts. Press 6 for the Thermostat Temperature sub-menu, followed by Right arrow key. The Keypad should display the first Thermostat (T01) along with its name and current temperature reading.
- 1e. Go into the Tasks sub-menu and select Economy Mode (Task 1). Press the # key to activate. When this task is activated the thermostat cooling setpoint should go to 85 degrees. Confirm this on the thermostat display.

## Appendix A

### Data Bus E.O.L. Termination - Very Important!

The M1 family features a true RS-485 differential data bus operating at 38,400 bits per second. This is relatively high speed by industry standards and ensures fast, accurate communications. EOL data bus terminating resistors are required to eliminate the possibility of reflection errors caused by varying cable lengths. Every data bus device; serial port expander, keypad, etc. and the control board has a built-in bus terminating resistor (120 Ohm) which is installed (activated) via a two pin header/jumper (two Gold Pins). The controls hardware pack includes two black shortening caps. When one of the shortening caps is placed on the two gold pins, installs (activates) the 120 Ohm terminating resistor across Data Lines A & B. Terminating resistors are marked JP2 on the keypads and JP1 on the expanders. From the factory, no terminating resistors are installed (activated).

**Warning! The RS-485 Data Bus must never have more than two terminating resistors header/jumpers installed.**

Ideally there should be no more than two home run cables (four wire) with daisy chained devices along each. The last device on each cable must have a terminating resistor installed (activated) via the gold two pin header/jumpers marked JP2 on keypads, JP1 on expanders. Place a black shortening cap (see hardware pack) onto the two gold pins to install a 120 Ohm resistor across data lines A and B. If there is only one data bus cable place a shortening cap on JP3 of main board. See alternate hookups below.

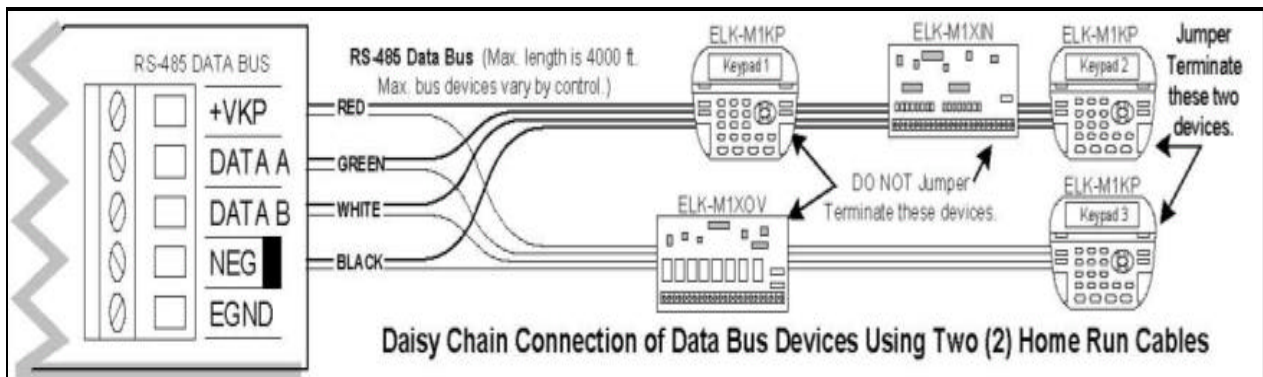

For those that prefer to home run wires, use six or eight conductor (CAT5 is ideal) cable. At each device, make a three-way splice of the data A, the device A wire (terminal), and a return data A1 wire (using one of the extra wires). At the control, make a two-way splice of the data A1 return wire (series connection) to the outgoing data A wire of the next cable. Repeat the data B wire. Remember to install a terminating jumper on the last wired and the control JP3 only! Electrically the data wires are now in a series. Connect the POS (+) and Neg (-) power wires of each device directly to the M1's + VKP and Neg (-) terminals. Do not series the power wires as this will cause unnecessary voltage loss.

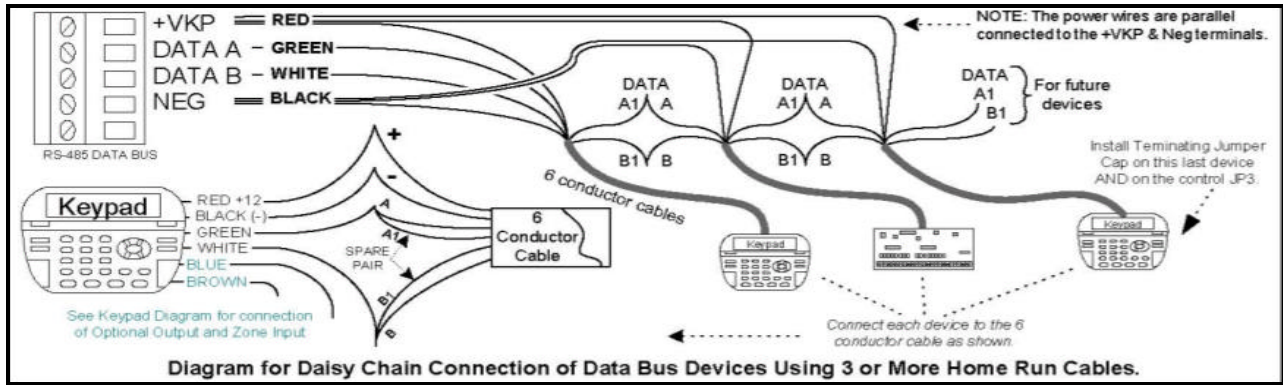

The ELK\_M1DBH. † Data BusHub accepts CAT5 or CAT6 cable with RJ45 plugs on the ends and does all the work of series connecting the DATA lines A & B. Terminate at the hub using the included RJ45 Terminating Plug in the first unused jack.

